

**CFC-FREE  
ULT-80 and ULT-95  
Low Temperature  
Bath/Circulators**

Thermo NESLAB Manual P/N U00487  
Rev. 04/27/00

**Instruction and Operation Manual**



# ULT-80 and ULT-95 Table of Contents

## Preface

Compliance .....	2
Unpacking .....	2
Warranty .....	2
NES-care .....	2
After-sale Support .....	2

## Section I Safety

Warnings .....	3
----------------	---

## Section II General Information

Description .....	4
Specifications .....	4

## Section III Installation

Site .....	5
Electrical Requirements .....	5
Plumbing Requirements .....	6
Fluids .....	6
Filling Requirements .....	6
Flow Control .....	7
Nitrogen Purge .....	7
Drain .....	7

## Section IV Operation

Start Up .....	8
Controller Keypad & Display .....	8
Changing a Value .....	9
Controller Displays .....	9
Operator's Loop .....	10
Setup Loop .....	10
Error Messages .....	13
High Temp/Low Liquid Level Safety .....	13
9-Pin Accessory Connector .....	14
Analog Interface .....	15

## Section V Maintenance & Troubleshooting

Service Contracts .....	16
Cleaning .....	16
Rust .....	16
Checklist .....	16
Service Assistance .....	18
Technical Support .....	18
ULT-95 Rear View .....	19
ULT-95 Left Side View .....	19
ULT-80 Right Side View .....	20
ULT-80 Left SideView .....	20
Additional Loops .....	21
Calibration Loop .....	22
Calibration Procedure .....	22

## Appendix A Serial Communications Protocol

## Appendix B Programming Software

## WARRANTY

## Preface

**Compliance** Products tested and found to be in compliance with the requirements defined in the EMC standards defined by 89/336/EEC as well as Low Voltage Directive (LVD) 73/23/EEC can be identified by the CE label on the rear of the unit. The testing has demonstrated compliance with the following directives:

LVD, 73/23/EEC	Complies with UL 3101-1:93
EMC, 89/336/EEC	EN 55011, Class A Verification EN 50082-1:1992 IEC 1000-4-2:1995 IEC 1000-4-3:1994 IEC 1000-4-4:1995

For any additional information refer to the Letter of Compliance that shipped with the unit (Declaration of Conformity).

**Unpacking** Retain all cartons and packing material until the unit is operated and found to be in good condition. If the unit shows external or internal damage, or does not operate properly, contact the transportation company and file a damage claim. Under ICC regulations, this is your responsibility.

**Warranty** Units have a warranty against defective parts and workmanship for one full year from date of shipment. See back page for more details.

### **NES-care Extended Warranty Contract**

- Extend parts and labor coverage for an additional year.
- Worry-free operation.
- Control service costs.
- Eliminate the need to generate repair orders.
- No unexpected repair costs.

Other contract options are available. Please contact Thermo NESLAB for more information.

### **After-sale Support**

Thermo NESLAB is committed to customer service both during and after the sale. If you have questions concerning the operation of your unit or the information in this manual, contact our Sales Department. If your unit fails to operate properly or if you have questions concerning spare parts or Service Contracts, contact our Service Department.

*Before calling*, please refer to the serial number label to obtain the following information:

- *BOM number* \_\_\_\_\_
- *Serial number* \_\_\_\_\_
- *Software version (see page 21)* \_\_\_\_\_

## Section I Safety

### Warnings

Make sure you read and understand all instructions and safety precautions listed in this manual before installing or operating your unit. If you have any questions concerning the operation of your unit or the information in this manual, contact our Sales Department (see After-sale Support).

**Performance of installation, operation, or maintenance procedures other than those described in this manual may result in a hazardous situation and may void the manufacturer's warranty.**

**Transport the unit with care. Sudden jolts or drops can damage the refrigeration lines.**

**Observe all warning labels.**

**Never remove warning labels.**

**Never operate damaged or leaking equipment.**

**Never operate the unit without cooling fluid in the bath.**

**Always turn off the unit and disconnect the line cord from the power source before performing any service or maintenance procedures, or before moving the unit.**

**Always empty the bath before moving the unit.**

**Never operate equipment with damaged line cords.**

**Refer service and repairs to a qualified technician.**

**For proper travel, the compressors' support springs are tightened prior to shipping. The springs (four per compressor) must be loosened before operating the unit. Remove the rear and side panels for easy access to the compressors and springs.**

In addition to the safety warnings listed above, warnings are posted throughout the manual. These warnings are designated by an exclamation mark inside an equilateral triangle with text highlighted in bold print. Read and follow these important instructions. Failure to observe these instructions can result in permanent damage to the unit, significant property damage, or personal injury or death.

## Section II General Information

### Description

The ULT-80 and ULT-95 are self-contained refrigerated bath/circulators. The units consist of a circulating pump; heater; stainless steel reservoir; microprocessor temperature controller; and a cascade configuration, air-cooled refrigeration system.

The refrigeration control is independent of the main power switch so that the compressor may be turned off to allow fast warm-up. The automatic load reset feature compensates the proportioning for changes in the bath load, thereby eliminating shifts in setpoint accuracy.

### Specifications

	ULT-80	ULT-95
<b>Temperature Range<sup>1</sup></b>	-80°C to +10°C	-90°C to -30°C
<b>Temperature Stability</b>	±0.03°C	±0.2°C
<b>Cooling Capacity<sup>2,3</sup></b>	250 watts at -70°C	340 watts at -80°C
<b>Work Area Dimensions<sup>4</sup></b> (L x W x D) <i>Inches</i> <i>Centimeters</i>	5 <sup>3</sup> / <sub>8</sub> x 7 x 9 <sup>1</sup> / <sub>2</sub> 13.7 x 17.8 x 24.1	2" DIA Fill Hole 5.1 cm Fill Hole
<b>Compressor</b>	2 x 1 H.P.	2 x 1.5 H.P.
<b>Heater</b>	1200 watts	1650 watts
<b>Working Volume</b> <i>Gallons</i> <i>Liters</i>	4.0 15.1	
<b>Unit Dimensions</b> (H x W x D) <i>Inches</i> <i>Centimeters</i>	47 <sup>1</sup> / <sub>2</sub> x 27 <sup>1</sup> / <sub>4</sub> x 17 <sup>3</sup> / <sub>4</sub> 120.7 x 69.2 x 45.1	47 x 32 <sup>1</sup> / <sub>8</sub> x 21 <sup>1</sup> / <sub>2</sub> 119.4 x 81.6 x 54.6
<b>Weight</b> <i>Pounds</i> <i>Kilograms</i>	336 152.4	370 168.0
<b>Pump</b>	"Z" Pump (Force/Suction)	"H" Pump (Increased agitation)
<b>Pump Head<sup>5</sup></b> <i>60 Hz</i> <i>50 Hz</i>	Max. Head 13' (3.9M) Max. Head 10' (3.3M)	Max. Head 31' (9.4M) Max. Head 21' (6.4M)
<b>Flow<sup>5</sup></b> <i>60 Hz</i> <i>50 Hz</i>	0-12.4 liters/minute at 0' Head 0-10.0 liters/minute at 0' Head	0-16.0 liters/minute at 0' Head 0-12.4 liters/minute at 0' Head

1. 50 Hz ULT-95 units -85°C to -30°C. ULT-80 +80°C temperature range units are available, these units have 2400 watt heaters (BOMs 180104201601 and 180106201601).

2. 200 watts for ULT-80, 50 Hz operation. 280 Watts for ULT-95, 50 Hz operation.

3. Cooling capacity is affected by: a) Recirculating temperature - cooling capacity decreases approximately 2% per °C below +20°C; b) Ambient temperature - cooling capacity will decrease at the rate of 1% per °F above 80°F.

4. Usable depth for ULT-80 is 8 inches.

5. Using fluid with specific gravity of 1.0.

## Section III Installation

### Site



**The refrigeration system requires that the unit must be located on a level surface. Never place the unit in a location where excessive heat, moisture, or corrosive materials are present.**

The unit should be located in a laboratory or clean industrial environment where ambient temperatures are inside the range of +50°F to +95°F (+10°C to +35°C).

Units have an air-cooled refrigeration system. Air is drawn through the front and discharged through side and rear panels. The unit must be positioned so the intake and discharge are not impeded. A minimum clearance of 3 feet (1 meter) on all four sides is necessary for adequate ventilation. Inadequate ventilation will reduce cooling capacity and, in extreme cases, can cause compressor failure.

Excessively dusty areas should be avoided and a periodic cleaning schedule should be instituted (see Section V, Cleaning).

The unit will retain its full rated capacity in ambient temperatures up to approximately +75°F (+24°C). Reduce the cooling capacity 1% for every 1°F above +75°F, up to a maximum ambient temperature of +95°F. In terms of °C, reduce the cooling capacity 1% for every 0.5°C above +24°C, up to a maximum ambient temperature of +35°C.

### Electrical Requirements



**The unit construction provides extra protection against the risk of electrical shock by grounding appropriate metal parts. The extra protection may not function unless the power cord is connected to a properly grounded outlet. It is the user's responsibility to assure a proper ground connection is provided.**

Refer to the serial number label on the rear of the unit to identify the specific electrical requirements of your unit.

Make sure the voltage of the power source meets the specified voltage,  $\pm 10\%$ .

## Plumbing Requirements

Before installing the unit to an instrument that previously used tap water as a cooling fluid, flush the instrument several times to remove any rust or scale that has built up. The manufacturer of the instrument should be able to recommend a cleaning fluid for their equipment.

The inlet/outlet connections are located on the right side of the control box. These connections are  $\frac{3}{8}$ " O.D. stainless steel serrated pipes, which will accept  $\frac{3}{8}$ " or  $\frac{5}{16}$ " I.D. tubing. Connect the pump inlet to the outlet of the external system. Connect the outlet to the inlet of the internal system.



**Ensure plugs are installed on the inlet/outlet if you are not circulating to an external system.**

Flexible tubing, if used, should be of heavy wall or reinforced construction. Make sure all tubing connections are securely clamped. Avoid running tubing near radiators, hot water pipes, etc. If substantial lengths of tubing are necessary, insulation may be required to prevent loss of cooling capacity.

It is important to keep the distance between the unit and the instrument being cooled as short as possible, and to use the largest diameter tubing practical. Tubing should be straight and without bends. If reductions must be made, they should be made at the inlet and outlet of the instrument being cooled, not at the unit.

If substantial lengths of cooling lines are required, they should be pre-filled with cooling fluid before connecting them to the unit.

## Fluids

The selected cooling fluid should have a viscosity of 50 centistokes or less at the lowest operating temperature. When operating below +8°C, use a non-freezing fluid. **Do not use corrosive fluids.**

## Filling Requirements

Fill the bath to within  $\frac{3}{4}$  inch of the top plate. Low fluid level in the bath can cause serious damage to the pump and the reservoir heater. Always maintain the level to within  $\frac{3}{4}$  inch of the top plate.



**Never run the unit when the bath is dry.**

When pumping to an external system, be sure to have additional bath fluid on hand to compensate for the loss of volume to that system.

## Flow Control

ULT-80s are equipped with a flow adjustment control knob. The knob is located directly in front of the control panel on the right side. When shipped, the flow is completely off. (Check that flow is off before starting the unit.)

To start flow, turn the knob in a counterclockwise direction until desired flow is obtained. Full flow is obtained by turning the knob approximately 3½ rotations.



**To avoid damage, do not overtighten the adjustment knob in either the open or closed position.**

## Nitrogen Purge

**NOTE:** This is a standard feature on ULT-95s, an optional feature for ULT-80s.

The nitrogen purge valve is designed to accept a constant flow of dry nitrogen into the reservoir. The nitrogen blankets the cooling fluid, preventing air oxidation and water absorption.

Remove the reservoir cover by removing the screws. Fill the reservoir with cooling fluid following the procedure listed above. Replace the cover and screws. Connect the nitrogen line to the valve on the reservoir cover.

A pressure regulator, set to 5 psig (.035 kg/cm<sup>2</sup>) or lower, should be used to prevent fluid overflow.

## Drain

A reservoir drain is located on the rear of the unit. The drain is a Parker 6PNBZ plug.



## Section IV Operation

### Start Up

Before starting the unit, check all electrical, plumbing, and inlet/outlet connections; and make sure the work area has been properly filled with bath fluid.

To start the bath, place the MAIN ON/OFF switch to the ON position. The pump will start and the controller will display the temperature of the fluid in the reservoir. (The controller may display **Er21** until the reservoir fluid temperature drops within 5°C of the unit's high-end temperature range, see page 13.) To start the refrigeration system place the REFRIGERATION ON/OFF switch to the ON position.

**NOTE:** For high-temperature units the refrigeration automatically shuts down above 35°C. The light in the REFRIGERATION ON/OFF switch will also extinguish. If rapid cool down is needed above 35°C use a Thermo NESLAB Aerocool heat exchanger which connects to the unit's pump fittings. If an Aerocool is not available, immerse a tap water cooling coil into the reservoir. Either of these methods can also be used to increase stability.

Once the cooling system has been turned off, it should remain off for approximately 10 minutes before attempting to restart. Failure to allow this time for pressure equalization within the refrigeration system could cause the compressors to cycle on their overloads.

### Controller Keypad & Display

The microprocessor controller maintains temperature using a Proportional-Integral-Derivative (PID) algorithm. It is designed with self-diagnostic features and easy to use operator interface.

The controller's **HEAT** indicator shows the status of the heater. The **HEAT** indicator is lit when the heater is on. The **HEAT** indicator flashes when the heater is pulsating.

The **REMOTE** indicator illuminates whenever the unit is configured to accept a remote setpoint. The controller's **SENSOR** indicator illuminates whenever the external sensor is selected. See Controller Displays on the next page.

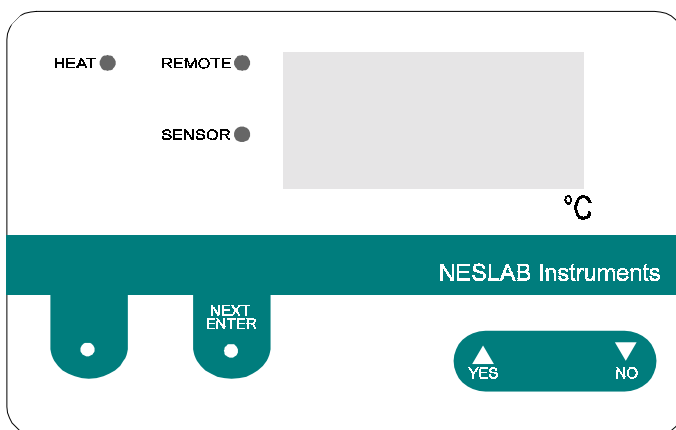

### **NEXT ENTER**

Use this key to scroll forward through the menus and also to accept and save changes.

### **YES, ▲**

This dual purpose key is used to answer yes to YES/NO questions or to increment numerical values upward for setting numeric values.

### **NO,**

This dual purpose key is used to answer no to YES/NO questions or to decrement numerical values downward for setting numeric values.

## **Changing a Value**

The **YES** key increments the value. The **NO** key decrements the value.

The display will flash as soon as either key is depressed, and will continue to flash until the **NEXT ENTER** key is pressed twice to accept the new value.

The new value will not be used by the controller until the **NEXT ENTER** key is depressed twice and the display stops flashing.

**NOTE:** If the **ENTER** key is not depressed twice within 10 seconds, the controller will time out and the new value will not be accepted. The controller will revert to the previous setpoint value.

## **Controller Displays**

An alphanumeric display presents numeric readings of various operating conditions within the bath. Display function is selected by pressing the appropriate keys to move through a menu of available information.

When the controller is first powered up it performs a quick self-test then enters the Operator's Loop. The Operator's Loop displays the bath temperature and is used to change the setpoint, see Figure 1 on next page. The Setup Loop can be accessed from the Operator's Loop by pressing and holding the key combinations shown on Figure 1. The Setup Loop is used to adjust the controller's PID parameters, select the internal or external sensor, select a remote setpoint source, and set the high/low temperature limits. It is also used to select and configure RS-232 operation. See Figure 2 on pages 11-12.

## Operator's Loop

When the controller is first powered up it enters the Operator's Loop, displaying reservoir fluid temperature. Press the NEXT ENTER key to view the setpoint.

SP displays the controller setpoint. The display will flash between SP and the actual setpoint number. Use the YES/NO keys to change the setpoint value. Once the desired setpoint is displayed, press the NEXT ENTER key twice.

**NOTE:** If the bath is controlled via RS-232 communications, the setpoint can not be changed from the keypad.

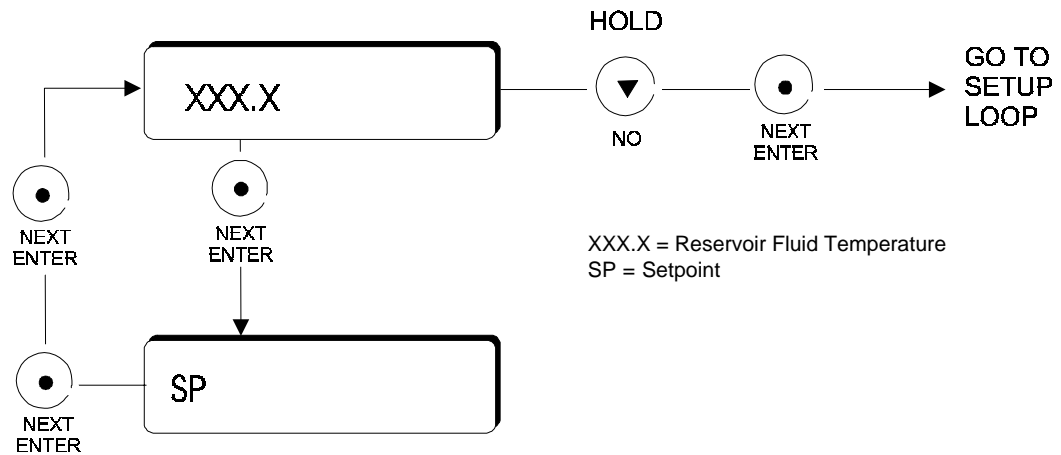

Figure 1 Operator's Loop

## Setup Loop

The Setup Loop is used to adjust the controller's PID parameters; select the internal (1) or external (2) sensor; select a remote setpoint source; set the high/low temperature limits; and select and configure RS-232 operation.

Enter the Setup Loop from the Operator's Loop by pressing and holding the NO key, then press the NEXT ENTER key. Use the YES/NO keys to adjust the values. Press the NEXT ENTER key twice to accept the new value.

While in the Setup Loop, if any key is not pressed during a one-minute time span, the controller will automatically return to the Operator's Loop temperature display.

**NOTE:** If the unit exceeds either temperature limit, the appropriate error message will flash, see page 13. The unit will not shut down (unless the temperature exceeds the high temperature safety setting, see page 13). You will also receive an error code if the optional external sensor is selected but it is not installed.

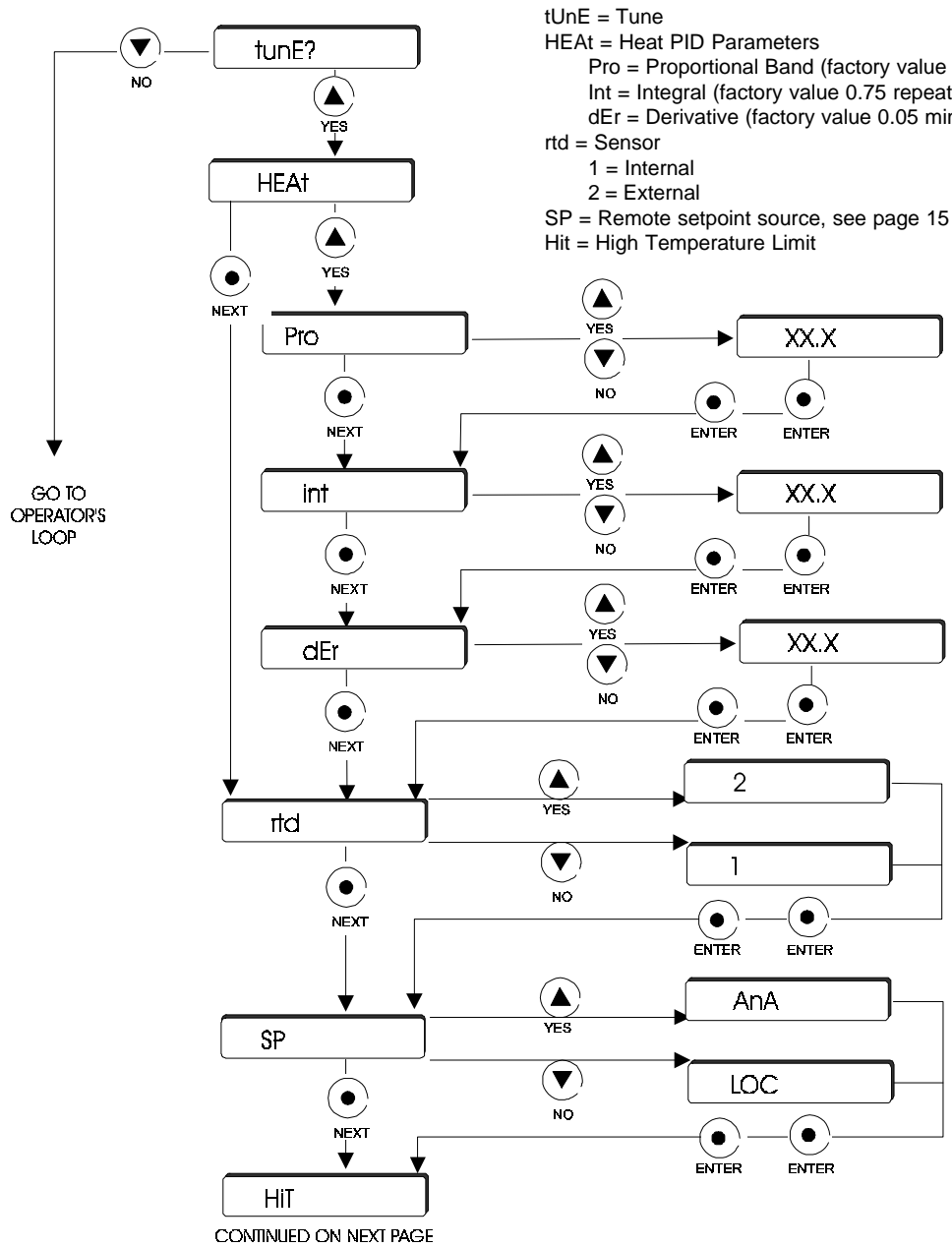

Figure 2 Setup Loop (1 of 2)

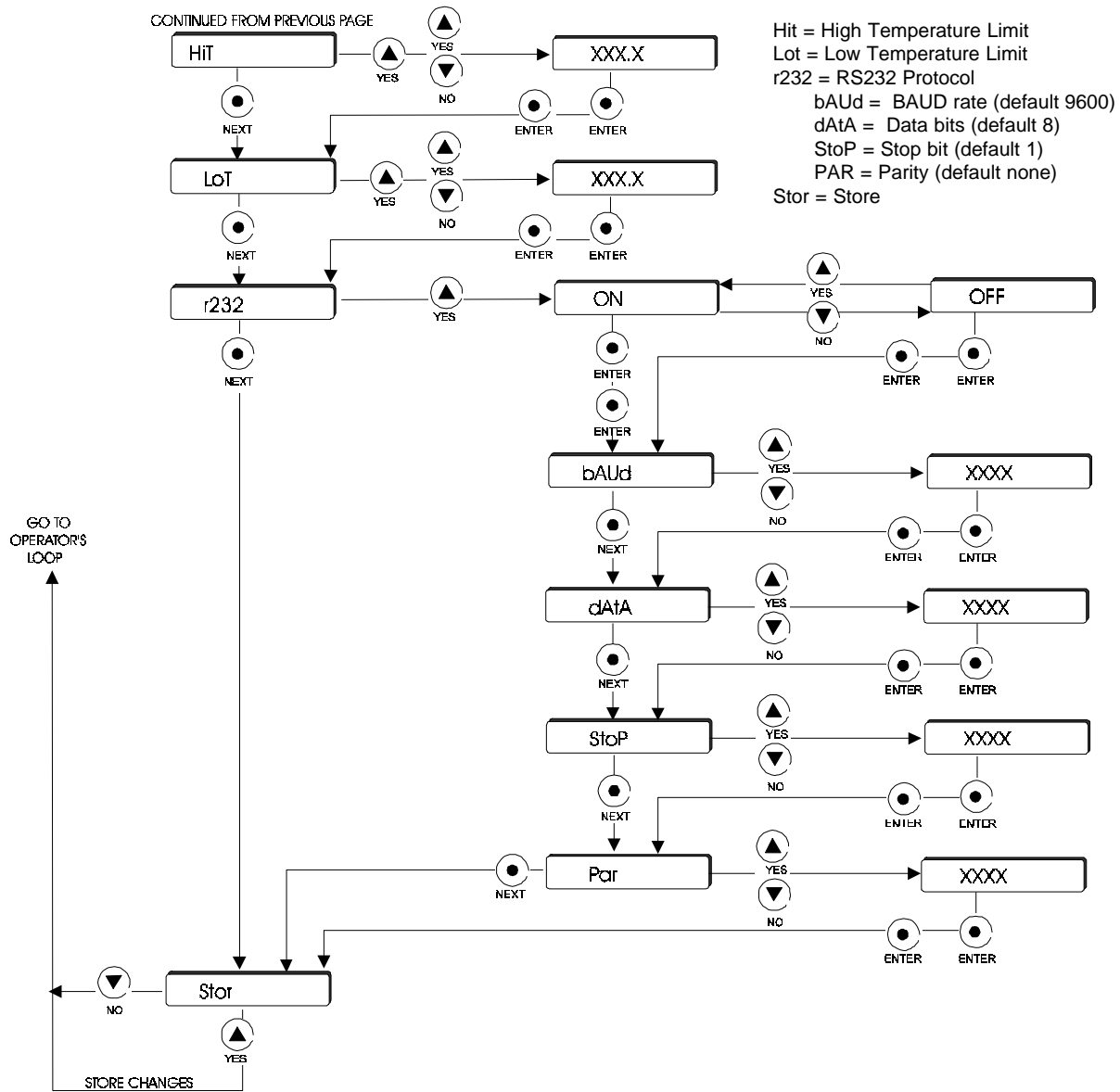

Figure 2 Setup Loop (2 of 2)

**NOTE:** Should you desire to return to the temperature display and abort *all* changes, keep pressing the **NEXT ENTER** until the display reads **Stor**, then press **NO**.

## Error Messages

Error	Action
Er00:	ROMChecksum
Er01:	RAM Test Failed
Er02:	Keypad Test Failed
Er04 - Er13:	Interrupt Error
Er14:	Synchronous Error
Er15:	Asynchronous Error
Er16:	Bad Calibration
Er19:	Low Temp Limit
Er21:	High Temp Limit
Er23:	RTD2 Shorted
Er24:	RTD2 Open/Not Installed
Er25:	RTD1 Shorted
Er26:	RTD1 Open
HTC:	High Temperature Cutout
Er52:	System Error

**NOTE:** On start up Er21 is active until the reservoir fluid temperature drops within 5°C of the unit's high-end temperature range. Errors 00 through 15 will lockup the controller keypad. Errors 00 through 03 may be cleared by depressing the NEXT ENTER key.

## High Temp/ Low Level Cutout

To protect your application, the adjustable High Temperature/Low Liquid Level Safety (HIGH TEMP/LOW LEVEL) ensures the heater will not exceed temperatures that can cause serious damage to your unit. A single temperature sensor, located on the heater coils in the bath, monitors both conditions. A High Temperature/Low Liquid Level fault occurs when the temperature of the sensor exceeds the set temperature limit.

In the event of a fault, the unit will shut down. The cause of the fault must be identified and corrected before the unit can be restarted.

The safety is not preset and must be adjusted during initial installation. To set the safety, locate the HIGH TEMP/LOW LEVEL SAFETY adjustment dial on the rear of the pump box. Turn the dial fully clockwise and turn the Power switch OFF then back ON.

Start the unit. Adjust the setpoint for a few degrees higher than the highest desired fluid temperature and allow the bath to stabilize at the temperature setpoint. Turn the HIGH TEMP/LOW LEVEL SAFETY dial counterclockwise until you hear a click and the unit shuts down. The FAULT LED will light to indicate a fault has occurred.

Cool the bath and then, without moving the adjustment dial, turn the Power switch OFF then back ON.

**NOTE:** The safety switch has a temperature range of 7°C to 180°C.

## 9-Pin Accessory Connector

The unit is equipped with two 9-pin D-connectors located on the rear of the control box. The female COMM is used for RS232 communication (see Appendix); the male is used with an optional external sensor.



### RS232 Pin Connections

Pin #	Function
1	No connection.
2	TX = Transmitted data from controller
3	RX = Received data to controller
4	No connection
5	GND = Signal ground
6	No connection.
7	CTS = Clear to send
8	RTS = Request to send
9	No connection

Hardware	Internal Connector	Mating Connector
	AMP Part# 745491-2	AMP Part# 745492-2

### Remote Sensor Connections

Pin #	Function
1	3-wire RTD connection A
2	No connection
3	No connection
4	3-wire RTD connection A
5	No connection
6	No connection.
7	3-wire RTD connection B
8	No connection
9	No connection

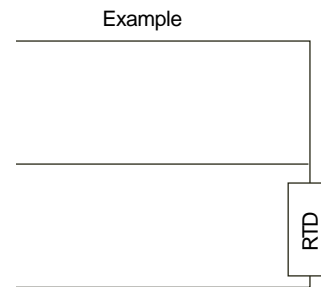

Hardware	Internal Connector	Mating Connector
	AMP Part# 745492-2	AMP Part# 745491-2

## Analog Interface

An 15-pin D subminiature female receptacle for analog interface is located on the rear of the control/pump box.

### Pin # Function

Pin #	Function
1	Chassis ground.
2	No connection.
3 - 5	No connection.
6	Analog Ground. The analog ground is physically separated from the power ground throughout the unit. To prevent offsets that result from ground currents, the analog and power grounds are only connected at the unit's power supply. Analog ground should only be used as a reference pin .
7	Temperature Out. The fluid temperature, as measured by the controller's sensor located in the reservoir, can be read at this pin. The temperature scale is 10mV/°C, referenced to analog ground, pin 6 (example: +150mV = +15.0°C).
8	No connection.
9	Power Ground (5V RTN).
10 - 13	No connection.
14	+5V. Power supply of +5VDC (15mA maximum).
15	Setpoint In. The temperature setpoint can be controlled by applying a known voltage to this pin. The temperature scale is 10mV/°C, referenced to analog ground, pin 6 (example: +230mV = +23.0°C). <b>Note:</b> The setpoint is updated only when the voltage represents a temperature within the setpoint limits.

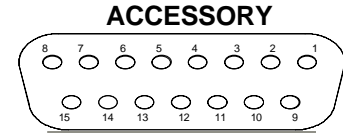

15 pin D-subminiature female receptacle

The analog setpoint signal (Setpoint In) is enabled using the unit's software. Using the Setup Loop discussed on pages 10 - 12, keep depressing the NEXT ENTER key until SP is displayed. Use the YES or NO key to display the desired mode, AnA for analog or LoC for local, then press NEXT ENTER twice to continue with the loop. **NOTE:** The last value entered is maintained when SP is changed from AnA to LOC or LOC to AnA. Store the changes.



## Section V Maintenance & Troubleshooting

### Service Contracts

Service Contracts are designed to provide extended life and minimal down-time for your unit. For more information, contact our Service Department.

### Cleaning

Periodically inspect the reservoir. If cleaning is necessary, flush the reservoir with a cleaning fluid compatible with both the circulating system (if applicable) and the cooling fluid. **Do not use steel wool; its too abrasive and will lead to rusting.** Dry the bath using a soft cloth.

Also, cooling fluid should be replaced periodically when operating at low temperatures. Moisture concentration in cooling fluid will increase with time leading to a build up of ice on the cooling coil.

Raise the temperature of the bath to deice the cooling coil. Shut the unit off, and replace the cooling fluid.

Periodic vacuuming of the condenser fins is necessary. The frequency of cleaning depends on the operating environment. It is recommended that a visual inspection of the condenser be made monthly after initial installation. After several months, the frequency of cleaning will be established.

### Rust

Stainless steel will rust if not properly used and maintained. Any damage, such as scratching or pitting, can cause rusting. The stainless steel parts exposed to bath fluids should be thoroughly cleaned periodically.

### Checklist

#### Unit Will Not Start

Check High Temperature/Low Level cutout (see Section IV, High Temp/Low Level Cutout).

Check all circuit breakers.

Check power source for correct voltage output.

Check line cord wiring (see Section III, Electrical Requirements).

### **Loss of Cooling Capacity**

Check cooling capacity specifications (see Section II, Specifications).

Check temperature setpoint.

Check to ensure that external heat load has not overcome the cooling capacity at the desired working temperature.

If the unit start and no cooling occurs, listen for a clicking sound from the inside of the unit. The clicking is an indication of compressor short-cycling. Check the following for causes of compressor short-cycling:

If the unit is shut off for any reason, allow the unit to remain off for approximately ten minutes before attempting to restart. The refrigeration compressor will short-cycle if time is not allotted for the equalization of refrigerant pressures.

Standard units are not designed for high temperature applications. If the cooling coils are subjected to temperatures above the maximum high temperature for the unit, compressor short-cycling will occur.

For high-temperature units the refrigeration automatically shuts down above 35°C. The light in the switch will also extinguish.

If the power source is 10% below the unit's voltage requirements, the compressor will short-cycle. Check power source for correct voltage output.

When operating below 8°C, a non-freezing solution must be added to the bath fluid. At low temperature, a higher concentration of the non-freezing solution is required to prevent ice build up on the unit's cooling coil. This ice build up will act as insulation and reduce the unit's cooling capacity. Raise the temperature of the bath to deice the cooling coil and increase the concentration of the non-freezing solution. Also, the bath fluid should be replaced periodically when operating at low temperatures. Moisture concentration in the bath fluid will increase with time leading to ice buildup.

### **Unit Will Not Heat**

Check the temperature setpoint to be certain that it is at your desired temperature (see Section IV, Operator's Loop).

Check the unit configuration in the controller's Setup Loop.

Continued on next page.

### **No Temperature Control**

If recirculating to an external system, do not overcome the cooling capacity of the unit. When the unit's cooling capacity is overcome, a loss of temperature control will result.

### **No External Circulation**

On ULT-80s, make certain adjustable Flow Control is open (turn counterclockwise).

Check for plug in external system line.

Recirculation will cease when pump head pressure is exceeded. Review pump specifications (see Section II, Specifications).

### **No serial communications**

All units are tested for serial communications before they leave the factory. Ensure the REMOTE indicator on the controller is illuminated.

Check all communications commands, they *must be exact*. See Appendix A.

Check communications settings. The protocol uses an RS-232 serial interface with the parameters: 9600 baud, 8 data bits, 1 stop bit and no parity.

Check all wiring for proper connections or possible shorts.

Software to verify serial communication is available from Thermo NESLAB.

## **Service Assistance**

If, after following these troubleshooting steps, your unit fails to operate properly, contact our Service Department for assistance (see Preface, After-sale Support). *Before calling* please obtain the following information:

*Part number*

*Serial number*

*Voltage of power source*

*Software version, see page 21*

## **Technical Support**

Our Service Department can provide you with a complete list of spare parts for your unit (see Preface, After-sale Support). *Before calling*, please obtain the following information:

*Part number*

*Serial number*

## ULT-95 Rear View

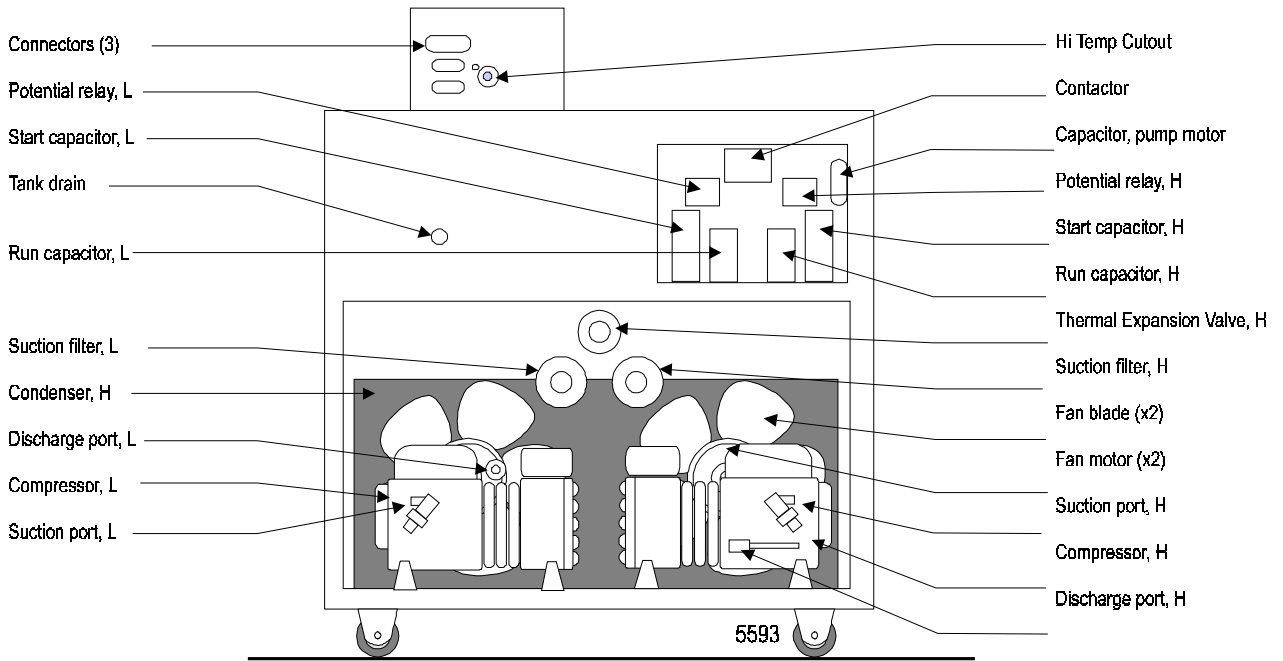

L = Low stage  
 H = High stage

## ULT-95 Left Side View

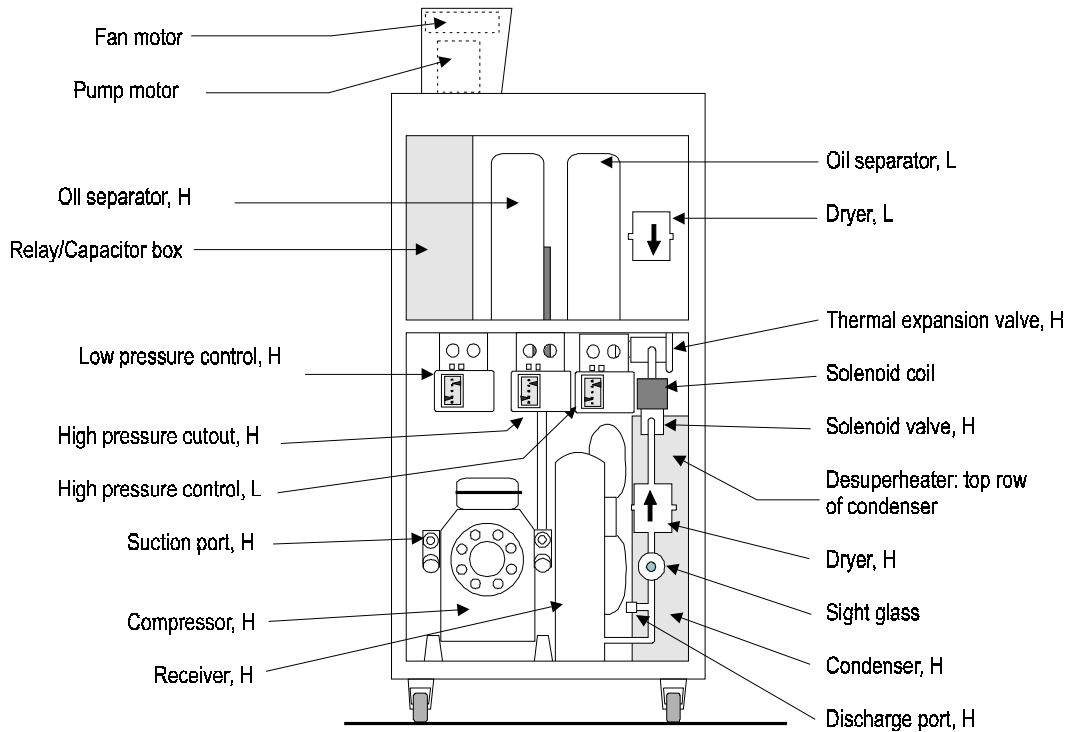

L = Low stage  
 H = High stage

### ULT-80 Left SideView

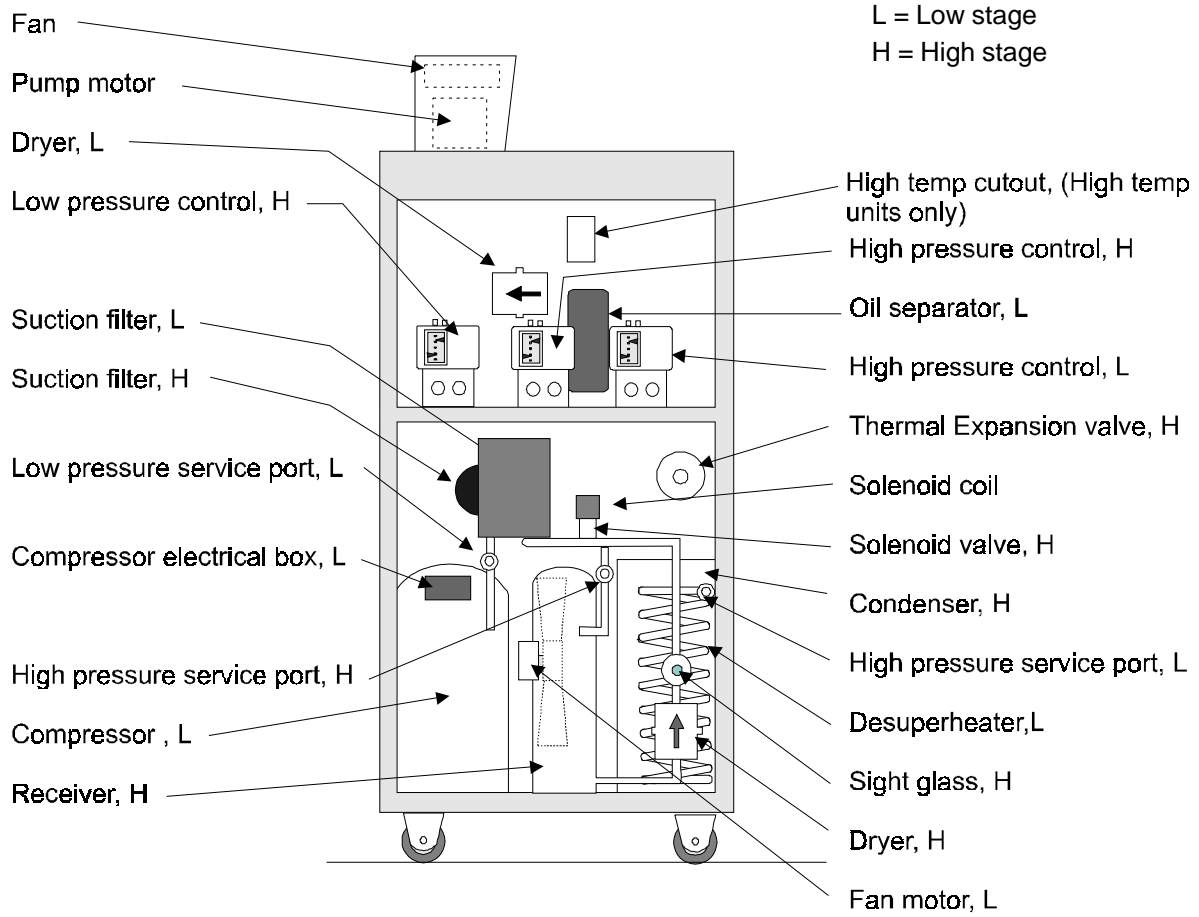

### ULT-80 Right Side View

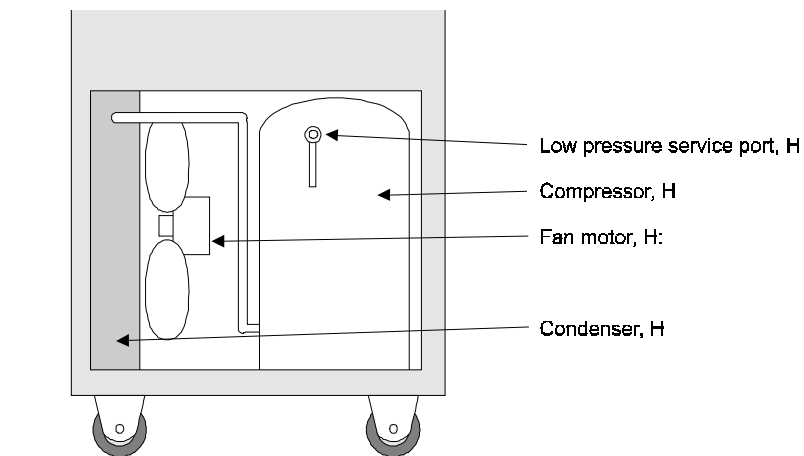

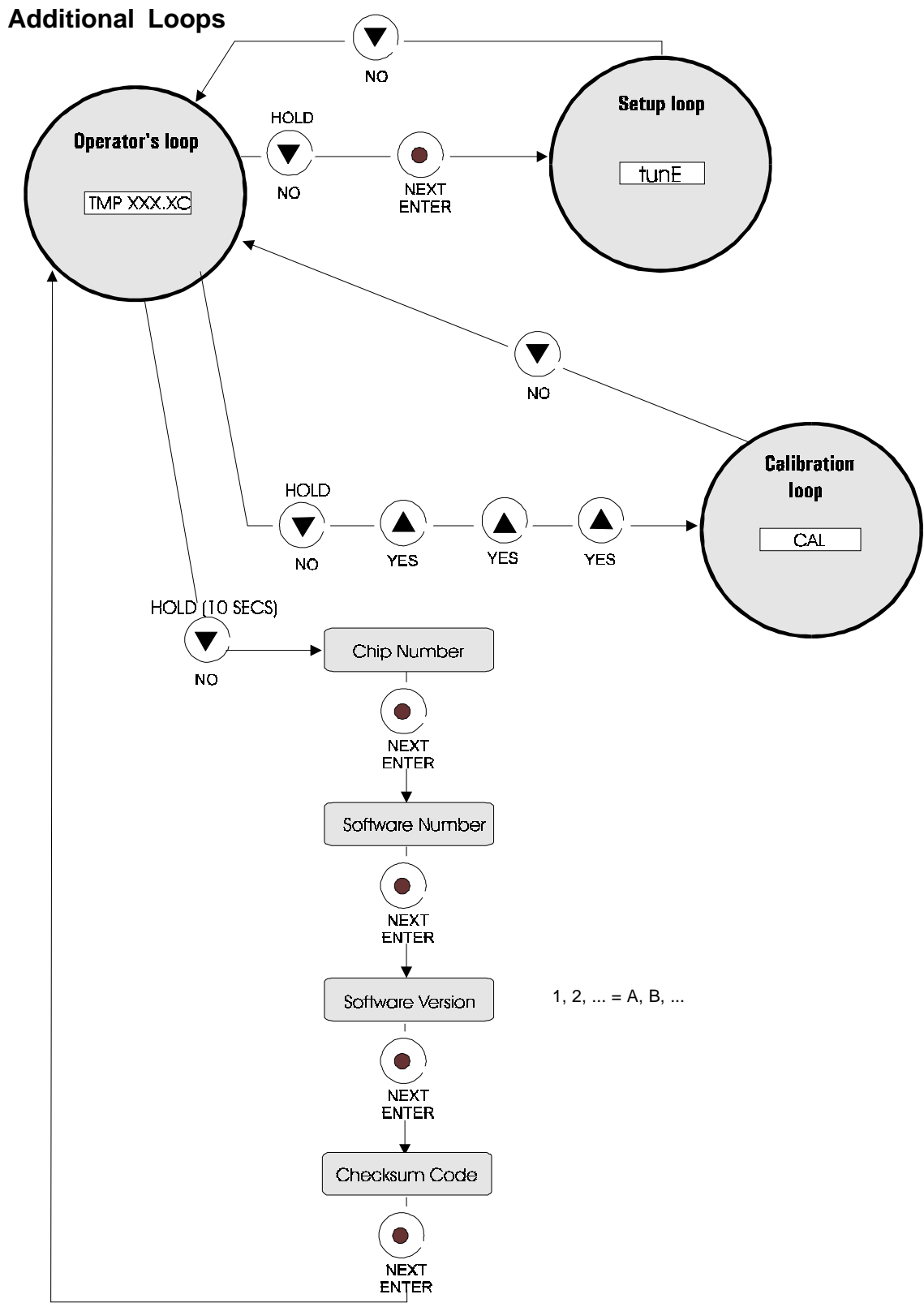

Figure 3 Changing Loops

## Calibration Loop

The Calibration Loop is used to calibrate the RTD high and low temperature. The controller's internal temperature sensor is factory calibrated. We recommend calibrating any external sensor.

Enter the Calibration Loop from the Operator's Loop by pressing and holding the NO key while pressing the YES key three times.

## Calibration Procedure

Install a calibrated reference thermometer in the bath. (For external mode, also install the sensor in the bath.) Place the cover on the unit.

The procedure uses the Operator's, Setup and Calibration Loops. In the Setup Loop place the unit in either the internal or remote RTD mode of operation (RTD1 = Internal , RTD2 = External). Return to the Operator's Loop and adjust the setpoint to an appropriate high-end temperature.

**NOTE:** When calibrating the external sensor ensure the controller's SENSOR indicator is illuminated.

Once the bath reaches the setpoint and stabilizes, go to the Calibration Loop and, as illustrated on the next page, enter the actual reference thermometer reading at either the r1H or r2H prompt.

Store the change and return to the Operator's Loop. Adjust the setpoint to an appropriate low-end temperature. Once the bath reaches the setpoint and stabilizes, return to the Calibration Loop and enter the reference thermometer reading at either the r1L or r2L prompt. Store the change.



**Do not pick points that are outside the safe operating limits of the unit and the fluid in your application.**

Analog In calibration is done by applying a 10.000Vdc signal for AiH, and a 0.000Vdc signal for AiL. Reference the appropriate pins on the ACCESSORY connector.

Analog Out calibration is done by measuring the appropriate pins on the ACCESSORY connector. Adjust the AoH to 1.000Vdc using the YES and NO keys then press ENTER twice. Adjust the AoL to 0.000Vdc using the YES and NO keys then press ENTER twice.

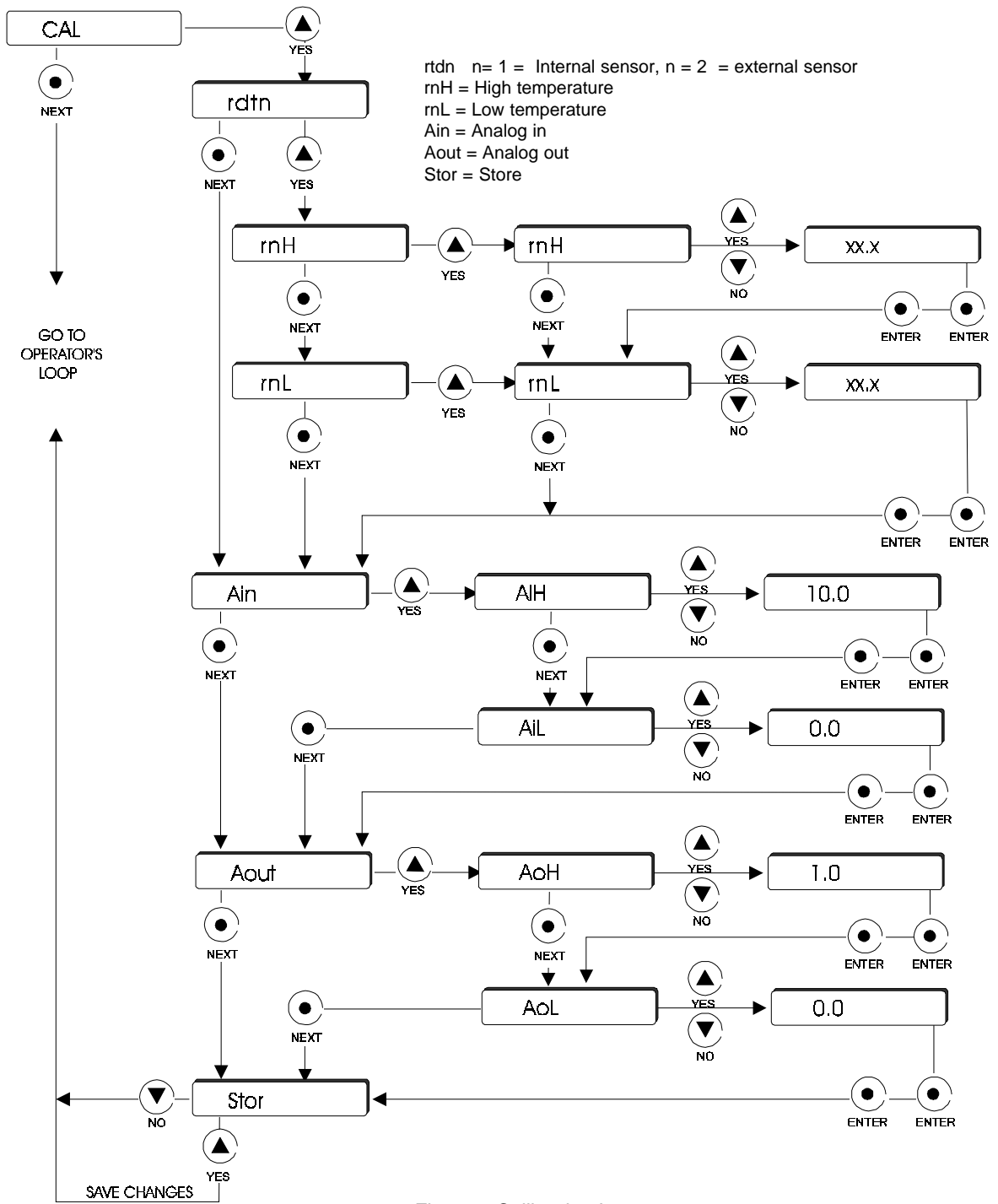

Figure 4 Calibration Loop

**NOTE:** To stor *all* changes, when the display reads **Stor** press **YES**. Should you desire to return to the temperature display and abort *all* changes, when the display reads **Stor** press **NO**.



Blank page.

## Appendix A Serial Communications Protocol

**NOTE:** This appendix assumes you have a basic understanding of communications protocols.

All data is sent and received in binary form, do not use ASCII. In the following pages the binary data is represented in hexadecimal (hex) format.

The Thermo NESLAB Serial Communications Protocol, NC, is based on a master-slave model. The master is a host computer, while the slave is the bath's controller. Only the master can initiate a communications transaction (half-duplex). The slave ends the transaction by responding to the master's query. The protocol uses an RS-232 serial interface with the default parameters: 9600 baud, 1 start bit, 8 data bits, 1 stop bit and no parity.

**NOTE:** Before the unit will communicate, RS-232 must be turned on in the controller's Setup Loop.

The unit can be controlled through your computer's serial port by using a standard 9-pin RS-232 connection on the rear of the temperature controller. Data transmit of the serial port connects to data read (pin 2) of the bath. Data read of the serial port connects to the data transmit (pin 3) of the bath.

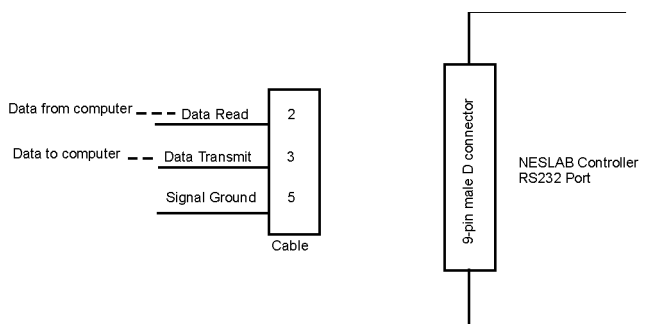

Communication cables are available. Contact our sales department for additional information.

All commands must be entered in the exact format shown in the tables on the following pages. Table 1 shows all commands available, their format and responses. Controller responses are either the requested data or an error message. The controller response *must* be received before sending the next command.

The host sends a command embedded in a single communications packet, then waits for the controller's response. If the command is not understood or the checksums do not agree, the controller responds with an error command. Otherwise, the controller responds with the requested data. If the controller fails to respond within 1 second, the host should re-send the command.

# NC Serial Communications Protocol

**NOTE:** All byte values are shown in hex, hex represents the binary values that must be sent to the bath. **Do not use ASCII.**

The framing of the communications packet in both directions is:

Checksum region								
Lead char	Addr-MSB	Addr-LSB	Command	n d-bytes	d-byte 1	...	d-byte n	Checksum
CA	00	01						

<i>Lead char</i>	CA (hex).
<i>Addr-msb</i>	Device address is 1
<i>Addr-lsb</i>	Most significant byte of device address is 00 hex.
<i>Command</i>	Least significant byte of device address is 01 hex.
<i>n d-bytes</i>	Command byte (see Table 1).
<i>d-byte 1</i>	Number of data bytes to follow (00 to 03 hex).
...	1 <sup>st</sup> data byte (the qualifier byte is considered a data byte).
<i>d-byte n</i>	...
<i>Checksum</i>	n <sup>th</sup> data byte.
	Bitwise inversion of the 1 byte sum of bytes beginning with the most significant address byte and ending with the byte preceding the checksum. (To perform a bitwise inversion, "exclusive OR" the one byte sum with FF hex.)

The master requests information by sending one of the Read Functions as shown in Table 1. Since no data is sent to the bath during a read request, the master uses 00 for the number of data bytes following the command byte.

The bath will respond to a Read Function by echoing the lead character, address, and command byte, followed by the requested data and checksum. When the bath sends data, a qualifier byte is sent first, followed by a two byte signed integer (16 bit, MSB sent first). The qualifier byte indicates the precision and units of measure for the requested data as detailed in Table 2.

As an example, the master requests to read internal temperature by sending:

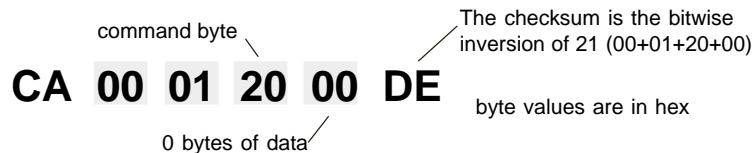

If the temperature is -10.5°C, the slave would reply:

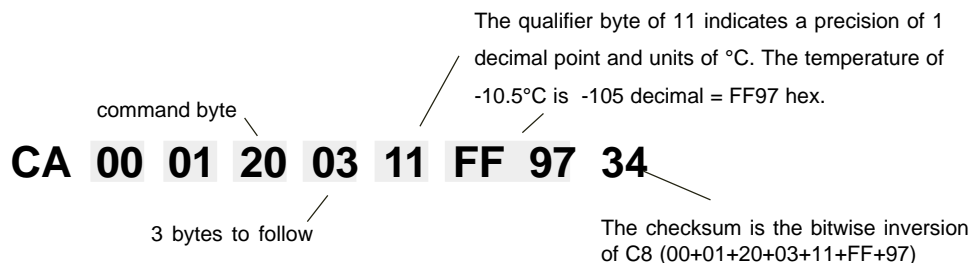

The master sets parameters in the bath by sending one of the Set Functions as shown in Table 1. The master does not send a qualifier byte in the data field. The master should be preprogrammed to send the correct precision and units (it could also read the parameter of interest first to decode the correct precision and units needed).

For example, if the master wants to set the setpoint to 30°C, it would send :

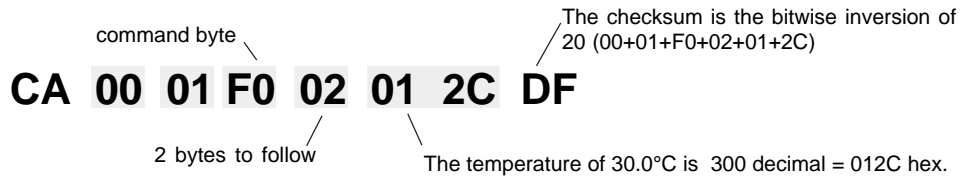

The slave responds:

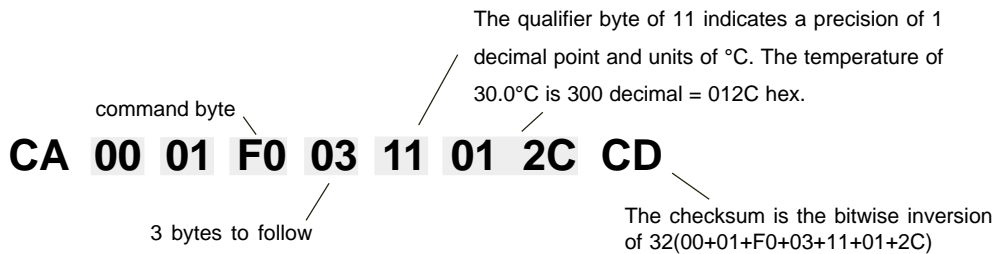

**Table 1 (All bytes are in hex)**

FUNCTION	MASTER SENDS	BATH RESPONDS
<b>READ</b>		
Read Internal Temperature	CA 00 01 <b>20</b> 00 DE	CA 00 01 <b>20</b> 03 qb d1 d2 cs
Read External Sensor	CA 00 01 <b>21</b> 00 DD	CA 00 01 <b>21</b> 03 qb d1 d2 cs
Read Setpoint (control point)	CA 00 01 <b>70</b> 00 8E	CA 00 01 <b>70</b> 03 qb d1 d2 cs
Read Low Temperature Limit	CA 00 01 <b>40</b> 00 BE	CA 00 01 <b>40</b> 03 qb d1 d2 cs
Read High Temperature Limit	CA 00 01 <b>60</b> 00 9E	CA 00 01 <b>60</b> 03 qb d1 d2 cs
Read Proportional Band (P)	CA 00 01 <b>71</b> 00 8D	CA 00 01 <b>71</b> 03 qb d1 d2 cs
Read Integral (I)	CA 00 01 <b>72</b> 00 8C	CA 00 01 <b>72</b> 03 qb d1 d2 cs
Read Derivative (D)	CA 00 01 <b>73</b> 00 8B	CA 00 01 <b>73</b> 03 qb d1 d2 cs
<b>SET</b>		
Set Setpoint (control point)*	CA 00 01 <b>F0</b> 02 d1 d2 cs	CA 00 01 <b>F0</b> 03 qb d1 d2 cs
Set Low Temperature Limit*	CA 00 01 <b>C0</b> 02 d1 d2 cs	CA 00 01 <b>C0</b> 03 qb d1 d2 cs
Set High Temperature Limit*	CA 00 01 <b>E0</b> 02 d1 d2 cs	CA 00 01 <b>E0</b> 03 qb d1 d2 cs
Set Proportional Band (P=1-99.9)	CA 00 01 <b>F1</b> 02 d1 d2 cs	CA 00 01 <b>F1</b> 03 qb d1 d2 cs
Set Integral (I = 0-9.99)	CA 00 01 <b>F2</b> 02 d1 d2 cs	CA 00 01 <b>F2</b> 03 qb d1 d2 cs
Set Derivative (D= 0-5.0)	CA 00 01 <b>F3</b> 02 d1 d2 cs	CA 00 01 <b>F3</b> 03 qb d1 d2 cs
<b>BATH ERROR RESPONSES</b>		
Bad Command	N/A	CA 00 01 <b>0F</b> 02 01 ed cs
Bad Checksum	N/A	CA 00 01 <b>0F</b> 02 03 ed cs
<b>MISCELLANEOUS</b>		
Request Acknowledge	CA 00 01 <b>00</b> 00 FE	CA 00 01 <b>00</b> 02 v1 v2 cs

command bytes shown in **bold**

qb = qualifier byte

d1,d2 = 16 bit signed integer of the value being sent or received

cs = the checksum of the string (see text)

ed = echo back of the command byte as received

v1,v2 = protocol version

\* = limited to the range of the bath

**Table 2**

**QUALIFIER BYTE**

10 hex	0.1 precision, no units of measure
20 hex	0.01 precision, no units of measure
11 hex	0.1 precision, °C units

Example: The temperature of 45.6 °C would be represented by the qualifier 11 hex, followed by the 2 bytes 01 C8 hex (456 decimal).

## Appendix B Programming Software

### NEScom Software

The Thermo NESLAB Communications Software is a user friendly software that allows you to automate your temperature control process. The software includes a 3½" disk, comprehensive operator's manual and a toll-free number to a trained technical staff.

NEScom Software allows you to write custom temperature programs for our Digital or Microprocessor based temperature control apparatus. Choose upper or lower temperature limits and monitor system status with an alarm. NEScom can also record your results on a user selectable graph. NesCom must be used with an IBM or 100% compatible computer.

Select from easy to use product icons.

Create graphs and charts.

Easily configure ramping functions which set the setpoint over time.

View pop-up alarm windows which display if an alarm condition occurred.

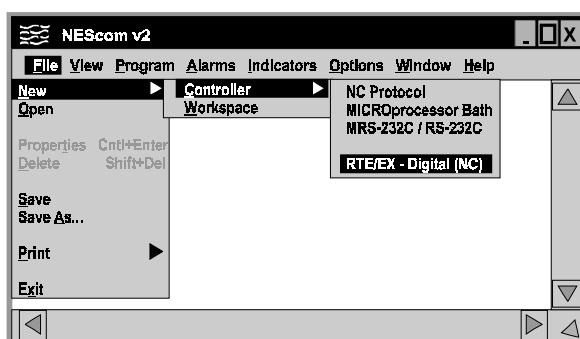

Select software functions from the easy to use pulldown menus.

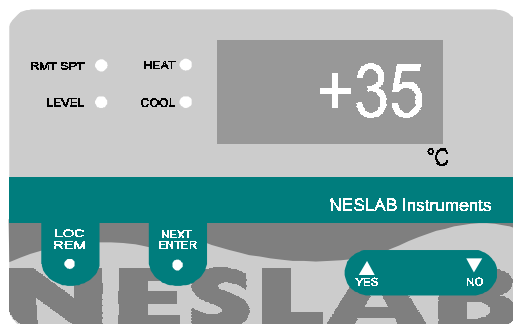

View a virtual controller screen which allows remote monitoring and operation of product control panel.

## WARRANTY

Thermo NESLAB Instruments, Inc. warrants for 12 months from date of shipment any Thermo NESLAB unit according to the following terms.

Any part of the unit manufactured or supplied by Thermo NESLAB and found in the reasonable judgment of Thermo NESLAB to be defective in material or workmanship will be repaired at an authorized Thermo NESLAB Repair Depot without charge for parts or labor. The unit, including any defective part must be returned to an authorized Thermo NESLAB Repair Depot within the warranty period. The expense of returning the unit to the authorized Thermo NESLAB Repair Depot for warranty service will be paid for by the buyer. Thermo NESLAB's responsibility in respect to warranty claims is limited to performing the required repairs or replacements, and no claim of breach of warranty shall be cause for cancellation or rescission of the contract of sales of any unit. With respect to units that qualify for field service repairs, Thermo NESLAB's responsibility is limited to the component parts necessary for the repair and the labor that is required on site to perform the repair. Any travel labor or mileage charges are the financial responsibility of the buyer.

The buyer shall be responsible for any evaluation or warranty service call (including labor charges) if no defects are found with the Thermo NESLAB product.

This warranty does not cover any unit that has been subject to misuse, neglect, or accident. This warranty does not apply to any damage to the unit that is the result of improper installation or maintenance, or to any unit that has been operated or maintained in any way contrary to the operating or maintenance instructions specified in Thermo NESLAB's Instruction and Operation Manual. This warranty does not cover any unit that has been altered or modified so as to change its intended use.

In addition, this warranty does not extend to repairs made by the use of parts, accessories, or fluids which are either incompatible with the unit or adversely affect its operation, performance, or durability.

Thermo NESLAB reserves the right to change or improve the design of any unit without assuming any obligation to modify any unit previously manufactured.

THE FOREGOING EXPRESS WARRANTY IS IN LIEU OF ALL OTHER WARRANTIES, EXPRESSED OR IMPLIED, INCLUDING BUT NOT LIMITED TO WARRANTIES OF MERCHANTABILITY AND FITNESS FOR A PARTICULAR PURPOSE.

Thermo NESLAB'S OBLIGATION UNDER THIS WARRANTY IS STRICTLY AND EXCLUSIVELY LIMITED TO THE REPAIR OR REPLACEMENT OF DEFECTIVE COMPONENT PARTS AND Thermo NESLAB DOES NOT ASSUME OR AUTHORIZE ANYONE TO ASSUME FOR IT ANY OTHER OBLIGATION.

Thermo NESLAB ASSUMES NO RESPONSIBILITY FOR INCIDENTAL, CONSEQUENTIAL, OR OTHER DAMAGES INCLUDING, BUT NOT LIMITED TO LOSS OR DAMAGE TO PROPERTY, LOSS OF PROFITS OR REVENUE, LOSS OF THE UNIT, LOSS OF TIME, OR INCONVENIENCE.

This warranty applies to units sold in the United States. Any units sold elsewhere are warranted by the affiliated marketing company of Thermo NESLAB Instruments, Inc. This warranty and all matters arising pursuant to it shall be governed by the law of the State of New Hampshire, United States. All legal actions brought in relation hereto shall be filed in the appropriate state or federal courts in New Hampshire, unless waived by Thermo NESLAB.